

Horizontal AC Drilling Motor.
 Continuous rating of
 motor is 400 HP.
 Continuous rating
 is at 600 VAC, 389
 Amperes, 39 Hertz,
 117/1170 RPM.

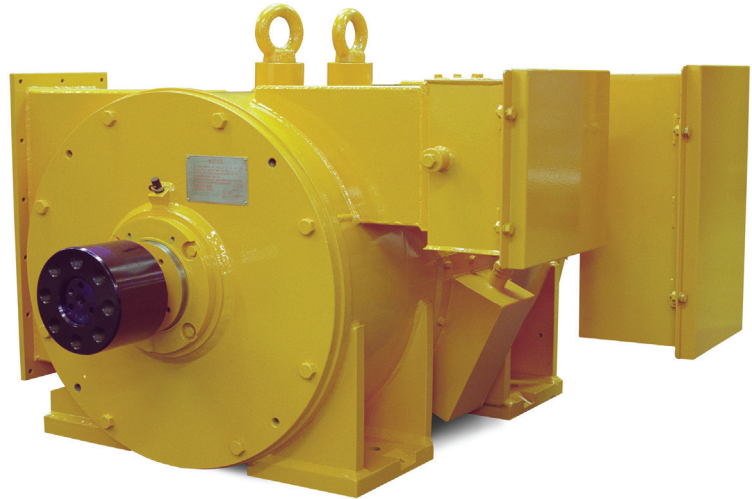

Joliet HTM400

Features:

- Class F Insulation.
- Inverter Duty/Constant torque
- Double/Single shaft extension with hub.
- OPE Insulated Bearing
- Pressurized connection box (IP54) mounted on left side of motor as viewed from non-drive end, with bolt on cable connections and terminations for pressure sensor, thermostat, space heater, lockout switch & blower unit. Connection box can be specified on right side.
- DE-Ball Bearing OPE–Roller Bearing
- Blower Assembly; Explosion Proof, 3 Phase, 60 Hz, 460 Volts, Providing 50 m3/min (1766 ft3/min) Ventilation Air.
- Pressure sensor, Explosion Proof
- New Space heater, 240 Volts, Explosion Proof
- Altitude Below 1000 Meters
- Approx. Weight: 1500 Kg.

Engineering Data:

- Direct Coupled Duty Only
- Full Load Torque: 1,800 lb-ft
- Motor Performance Curve–Refer to Fig.1
- Ventilation 50 m3/min. 1700 ft3/ min
- Locked Rotor Current : 655% / (2424 (A))
- Locked Rotor/Breakdown Torque : 164% / 250%
- Insulation Class F
- Maximum Service Speed: 1170mn-1
- Over speed: 1404mn-1 (7 minutes)
- No/Load Vibration: 0.8 mms/s (rms)
- Noise (@ No-Load): Approx. 90 dB (A) at 1m from motor frame
- Bearing Type: Gear Side: Ball Bearing;
Opp. Gear side: Roller Bearing

Rating:	Continuous
Output (HP)	400
Output (KW)	298
Voltage (V)	600
Current (A)	389
Speed (min-1)	1170
Frequency (HZ)	39
Efficiency (%)	94.6
Power Factor (%)	82.1
Slip (%)	1.17

HTM400 Dimensions

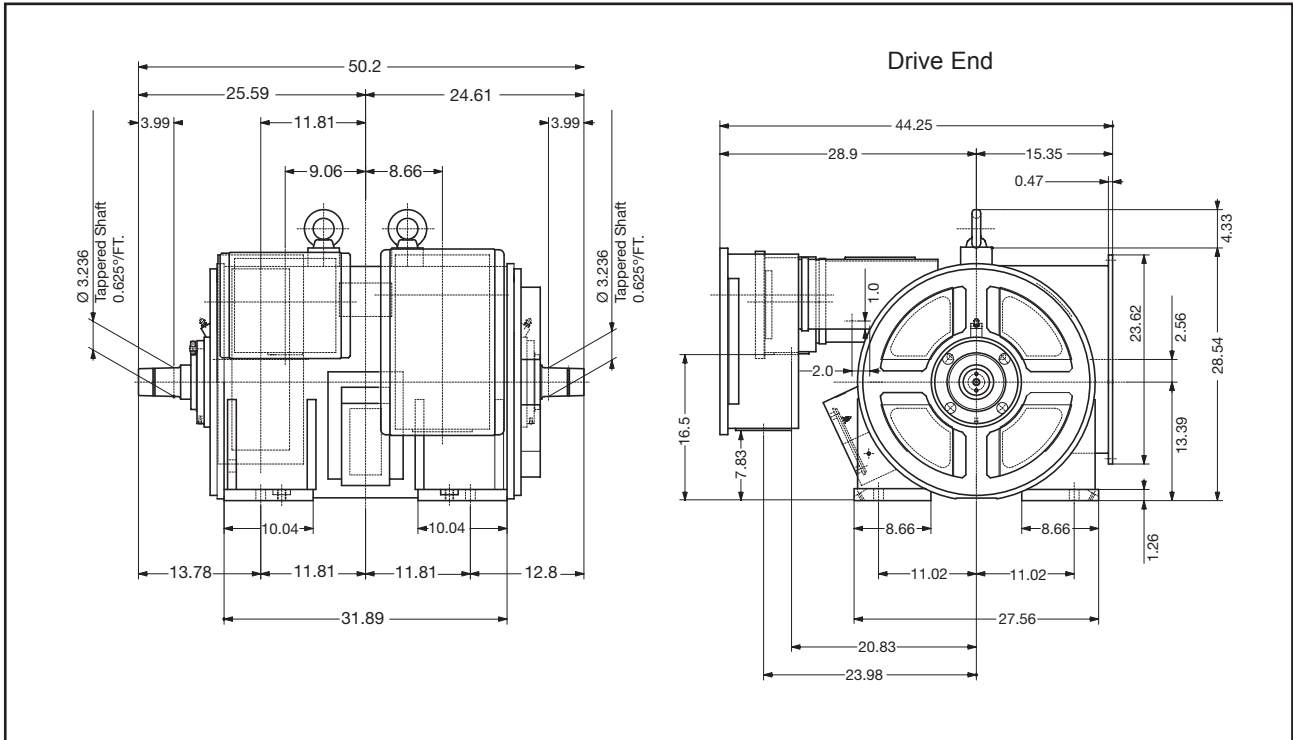
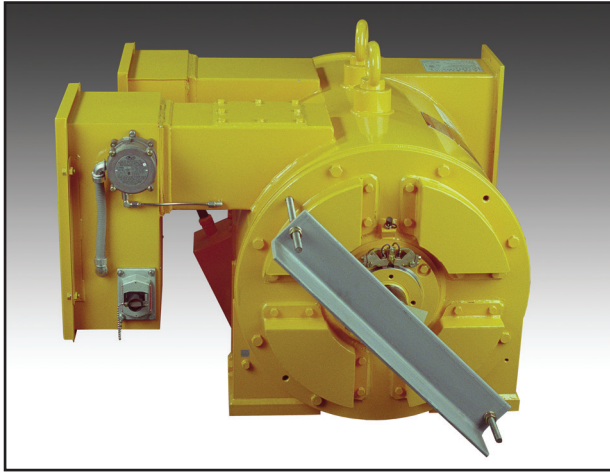

Not to be used for construction.

Approximate Weight: 1,500Kg

Dimensions are in inches.



Joliet Equipment Corporation
P.O. Box 114
Joliet, Illinois 60434 USA

(800) 435-9350 (713) 467-7559
Fax: (713) 467-7887
www.joliet-equipment.com • tractionmotors.com